



NIAGARA

**General Catalogue
Catálogo General
Catalogue général**



NIAGARA

FUTURE INTELLIGENT PUMPS



North America:

Head Office, Canada:

- 📍 Address: 4 Laurier Ave, Milton, Postal Code: L9T4V2, Ontario, Canada.
- ☎ Tel: +1 (514) 550 5578
- ✉ Email: sales@niagarapumps.ca

USA:

- 📍 Address: 8450 Cambridge street zip code 77054 Houston Texas.
- ☎ Tel: +1 (713) 363 1585
- ✉ Email: usa@niagarapumps.ca



Europe:

Sweden:

- 📍 Address: Lisa sass Gatan 12 Gothenburg – Sweden.
- ☎ Tel: +4 (670) 099 1626
- ✉ Email: sweden@niagarapumps.ca

Turkey:

- 📍 Address: FATIH MAH URFALILAR CAD, NO 9A, Esenyurt, Istanbul-Turkey.
- ☎ Tel: +9 (537) 523 9069
- ✉ Email: turkey@niagarapumps.ca



Middle East:

- 📍 Address: Liwara 1, Shaikh Rashid Bin Humaid St. Ajman, UAE
- ☎ Tel: +9 (715) 5269 3552
- ✉ Email: uae@niagarapumps.ca

FBZ

Energy saving smart circulation pump
Bomba circulación de ahorro energía
Pompe circulation économie d'énergie



FBZ-6



FBZ-8

DESCRIPTION/DESCRIPCIONES/DESCRIPTION

- The control panel allows one to select the preferred work curve by means of three programmes.
- El panel de control permite seleccionar la curva de trabajo preferida mediante tres programas.
- Le panneau commande permet sélectionner la courbe travail préférée au moyen de trois programmes.

	PP1-PP2-PP3 PROPORTIONAL PROGRAMME PROGRAMA PROPORCIONAL PROGRAMME PROPORTIONNEL	Pressure/delivery changes proportionally. Presión/entrega cambia proporcionalmente. Pression/débit modifie proportionnellement.
	CP1-CP2-CP3 CONSTANT PROGRAMME PROGRAMA CONSTANTE PROGRAMME CONSTANT	Pressure constant with variation of delivery. Presión constante con variación de entrega. Pression constante de variation du débit.
	I - II - III SPEED PROGRAMME PROGRAMA DE VELOCIDAD PROGRAMME DE VITESSE	Fixed speed curves of operation. Curvas de velocidad fija de funcionamiento. Courbes de fonctionnement à vitesse fixe.

DIMENSIONS AND WEIGHT/DIMENSIONES Y PESOS/DIMENSIONS ET POIDS

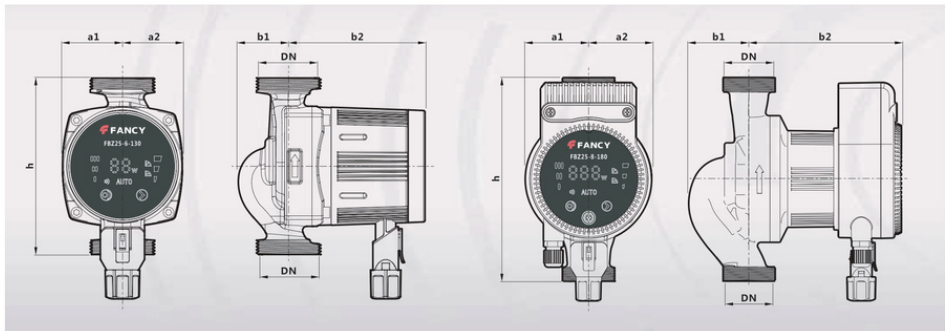

NIAGARA

TECHNICAL DATA/DATOS TÉCNICOS/DONNÉES TECHNIQUES

MODEL MODELO MODÈLE	Power W	Voltage V	Max flow m³/h	Max Head m	DN mm	h mm	a1 mm	a2 mm	b1 mm	b2 mm
FBZ25-6-130	15-35	220V	3.1	6	40 to 25	130	44	44	35	103
FBZ25-6-180	15-35	220V	3.1	6	40 to 25	180	44	44	35	103
FBZ32-6-130	15-35	220V	3.1	6	50 to 32	130	44	44	35	103
FBZ32-6-180	15-35	220V	3.1	6	50 to 32	180	44	44	35	103
FBZ25-8-180	25-125	220V	8.3	9	40 to 25	180	56	56	54	135
FBZ32-8-180	25-125	220V	8.3	9	50 to 32	180	56	56	54	135

PERFORMANCE CURVE/CURVA DE RENDIMIENTO/COURBE DE PERFORMANCE

